

RDG140

RDG160

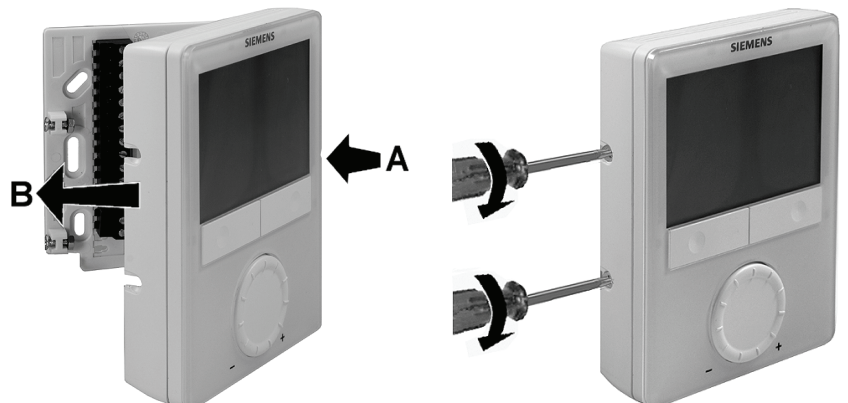
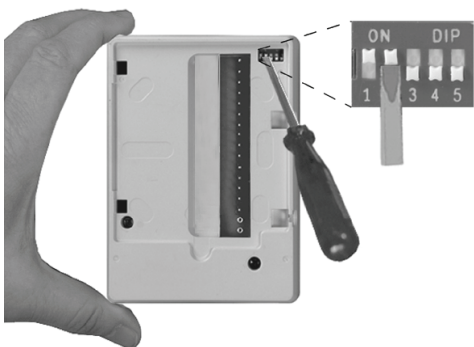
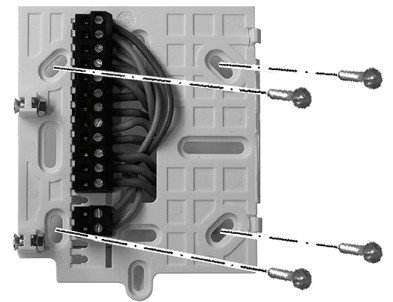
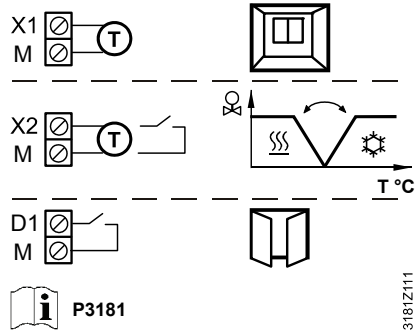
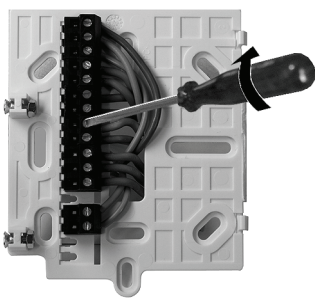
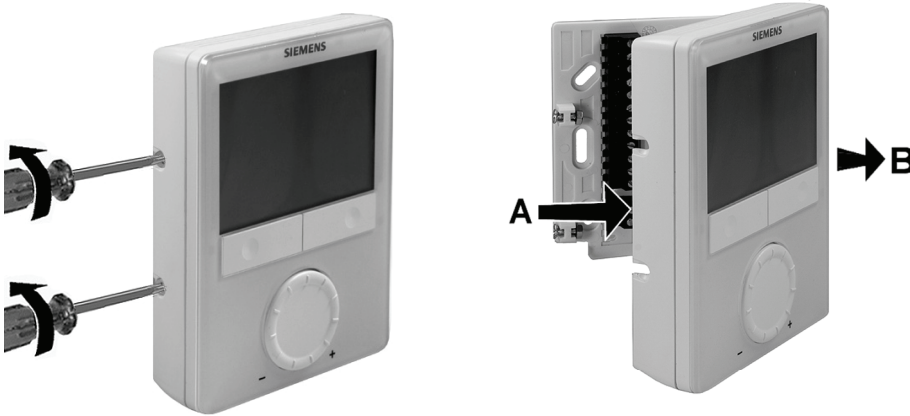
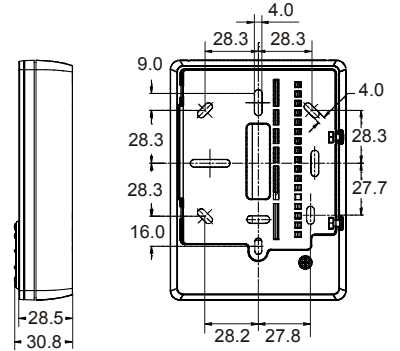
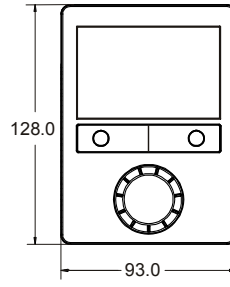
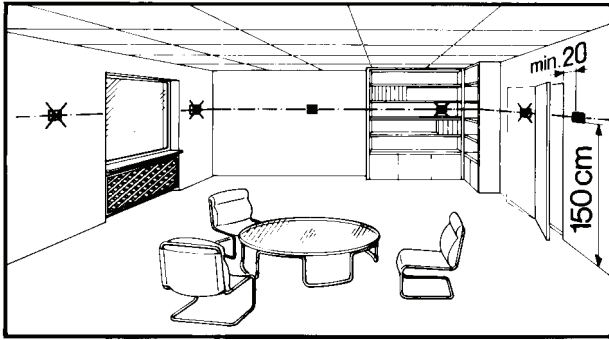

1) ① ⑤

2) **a** Outputs → DC 0...10 V / DC 10...0 V

3) ON OFF 1 2 3 and ON OFF 4 5

4)

5) G,G0 / 24 VAC: → P01...Pn

i → P3181

RDG140...		RDG160...	
a	V1 / Y10	DC 10..0 V DIP 4 ON	DC 10..0 V DIP 4 ON
① 2-pipe		DC 0..10 V DIP 4 OFF	DC 0..10 V DIP 4 OFF

RDG140...		RDG160...	
a	V1 / Y10	DC 10..0 V DIP 4 ON	DC 10..0 V DIP 4 ON
	V2 / Y20	DC 10..0 V DIP 5 ON	DC 10..0 V DIP 5 ON
		DC 0..10 V DIP 5 OFF	DC 0..10 V DIP 5 OFF
② 2-pipe & el. heater			
③ 2-pipe & radiator			
④ 4-pipe			
⑤ 2-stage			

	en	de	fr	it	es	cs	tr
①	2-pipe fan coil	2-Rohr Ventilator-konvektor	Ventiloconvecteur 2 tubes	Fan coil 2 tubi	Fancoil a dos tubos	2-trubkový fan-coil	2 borulu fan coil
②	2-pipe & el. heater	2-Rohranwendung & Elektroheizer	Application 2 tubes & batterie électrique	Fan coil 2 tubi con batteria elettrica di riscaldamento	2 tubos & batería eléctrica	2-trubkový fan-coil & el. ohřev	2 borulu& elk. Isıtıcı
③	2-pipe & radiator	2-Rohranwendung & Radiatorventil	Application 2 tubes & vanne thermostatique	Fan coil 2 tubi e radiatore	2 tubos & rad	2-trubkový fan-coil & radiátor	2 borulu& radyatör
④	4-pipe fan coil	4-Rohr Ventilator-konvektor	Ventiloconvecteur 4 tubes	Fan coil 4 tubi	Fancoil a 4 tubos	4-trubkový fan-coil	4 borulu fan coil
⑤	2-stage	2-Stufen-Anwendung	Application à 2 étages	2 stadi	2 etapas	2-stupňový	2 kademe